



FEM

European Materials Handling Federation
www.fem-eur.com

Product Group /
Elevating Equipment



December 2017

FEM 11.004 rev.1

Guidance on Dock Leveller Selection

Including:

1. Rated Load for Dock Levellers
2. Deck plate awareness

The European Materials Handling Federation (FEM) represents manufacturers and suppliers of Materials Handling Equipment across Europe. The members of its Elevating Equipment Product Group have recognised that there is a need to make customers, specifiers and end users aware of the importance of any issues effecting Dock Levellers built to *EN 1398:2009 – Dock levellers – Safety Requirements*. Two such issues are detailed below.

Issue 1: Rated Load for Dock Levellers

It is apparent that capacities are being displayed on Dock Levellers, their sales literature, and/or their technical specifications which are misleading, allowing some manufacturers to seemingly gain a competitive advantage.

The relevant standard, EN 1398:2009, generally uses the term “Rated Load” throughout. It defines the Rated Load as:

“weight of the greatest moving load (including goods, persons and transport equipment for goods) for which the dock leveller is designed”

EN 1398:2009 also states that each Dock Leveller shall have the “capacity of the Dock Leveller”, “easily visible and permanently fixed”.

Rated Load = Capacity

The test procedure for a Dock Leveller, as defined in EN 1398:2009, includes applying a safety factor to the dead load applied, in order to account for dynamic factors. This is because a load moving at speed, and/or braking harshly, will place more loading on the Dock Leveller than when it is not moving. This, however, is part of the test procedure only, and does not sanction the use of different figures and definitions of Capacity or Rated load to be quoted.

The Capacity of a Dock Leveller, which must be identified on the Dock Leveller, is the total load that can be applied to the Dock Leveller, whether it be moving, braking or stationary.

Issue 2: Deck plate awareness

EN 1398:2009 specifies the design and testing methods required to build 'safe' equipment, however one issue has been recognised which affects the long term life of this equipment and must be considered by suppliers/manufacturers of the equipment at the time of specifying.

As an example; a typical 6,000Kg capacity Dock Leveller will operate for many years if used with a Fork Lift Truck (total load 6,000Kg) with 'normal' rubber tyres, but the upper deck structure can suffer localised damage (requiring potentially expensive repair bills) over time if used with a Pallet Truck or Reach Truck (total load 2,000Kg) with small hard wheels due to the significantly higher pressure such equipment imposes on the Dock Leveller.

The chart below shows some typical examples of common Materials Handling Equipment to highlight the differences.

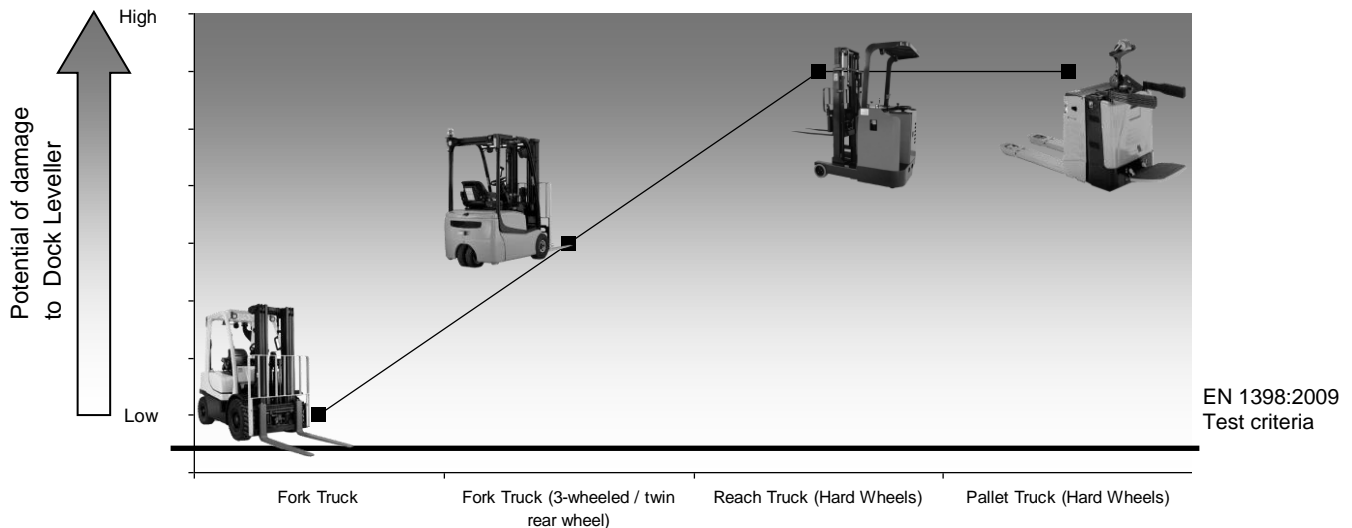

In other words, it is not only the capacity that is important, but the materials handling equipment used.

Check with the supplier/manufacturer that the equipment you are buying is not only capable of supporting the total load you require, but that it is suitable to work with your chosen Materials Handling Equipment.

For further assistance, please contact the FEM Elevating Equipment Product Group, as below, who will put you in touch with a member company who will be happy to assist you in specifying the correct equipment for your application. Details can be found on our website: www.fem-eur.com (section: Product Groups > Elevating Equipment).

Tim Faithfull

Secretary

FEM Elevating Equipment Product Group

tim.faithfull@admin.co.uk

0044 1439 772 968

0044 208 253 4504

The recommendations and advice contained in this Guidance Note are based on specifications, procedures and other information that have been collected from the FEM from its members. They represent what is, as far as FEM is aware, the best available data at the time of publication on the instruction and use of the equipment concerned in the general conditions described and are intended to provide guidance for such use.

The suitability of this Guidance Note must be determined by the judgement of the person applying it in accordance with the conditions in which use is envisaged and subject to all relevant statutory requirements.

FEM accepts no responsibility for the recommendations, advice, statements and conclusions expressed or implied and gives no warranty, representation or assurance with respect to the accuracy or validity of the same.



FEM

European Materials Handling Federation
www.fem-eur.com

© Copyright FEM