

CONGRESS FEM 2010
30 SEPTEMBER- 2 OCTOBER

ISTANBUL



Seismic Aspects of Warehouses The USA Research on Earthquake Response

By

Teoman Pekoz, PhD

Consultant to the RMI

Professor Emeritus Cornell University

Presentation Outline

- **Information Exchange with Europe and within Europe (covered by previous speakers)**
- **Video on US Approach (8 Minutes)**
 - **Shake Table tests**
 - **Base Isolator Approach**
- **FEMA Document**
- **New (2010) RMI Specification and Connection Testing**
- **Current research**
 - **Down aisle stiffness**
 - **Cross Aisle stiffness**
 - **Column base fixity**

RIDG-U-RAK VIDEO

FEMA - 460

- Features



Seismic Considerations for Steel Storage Racks Located in Areas Accessible to the Public

FEMA 460 – September 2005



2010 RMI SPECIFICATION

- Features



2008 Version from

<http://www.mhia.org/vango/core/orders/product.aspx?catid=32&productid=65>

Hysteretic behavior testing

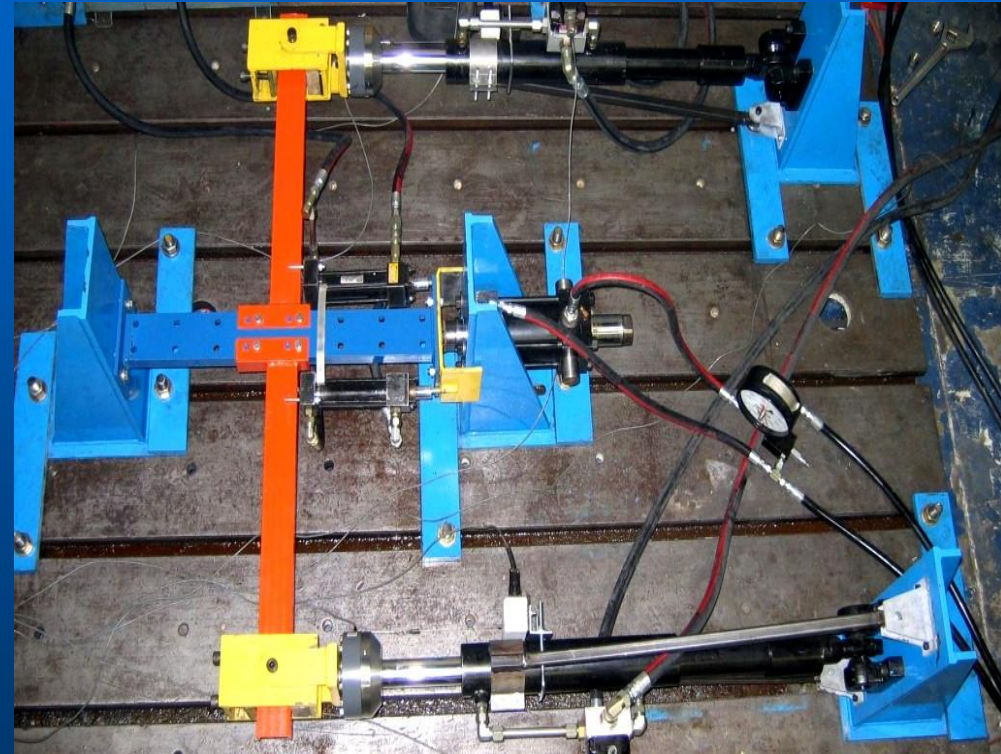
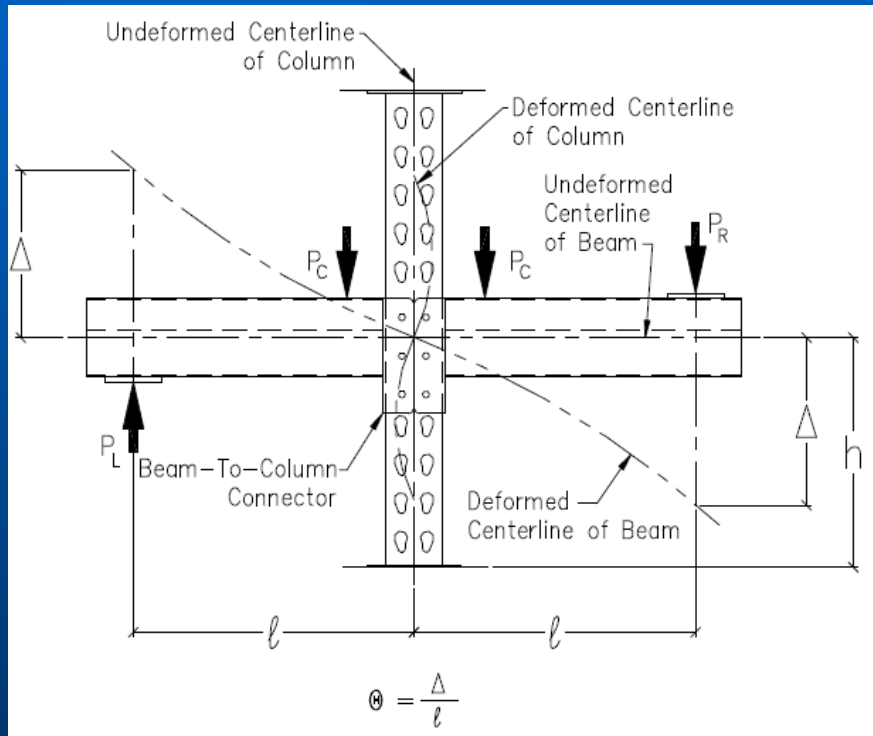

Hysteretic behavior

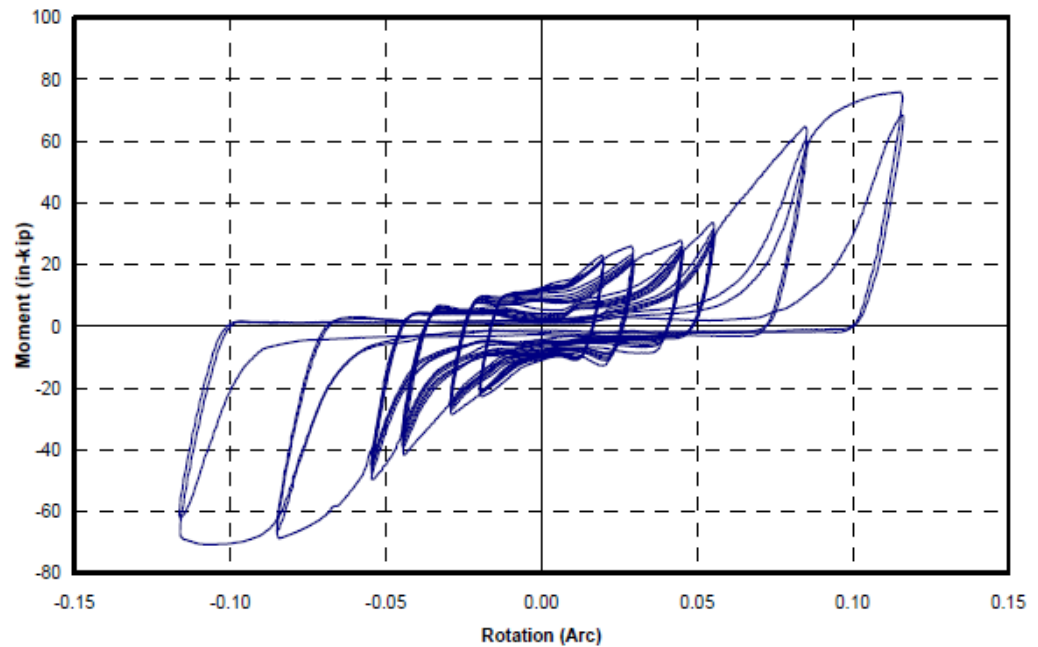
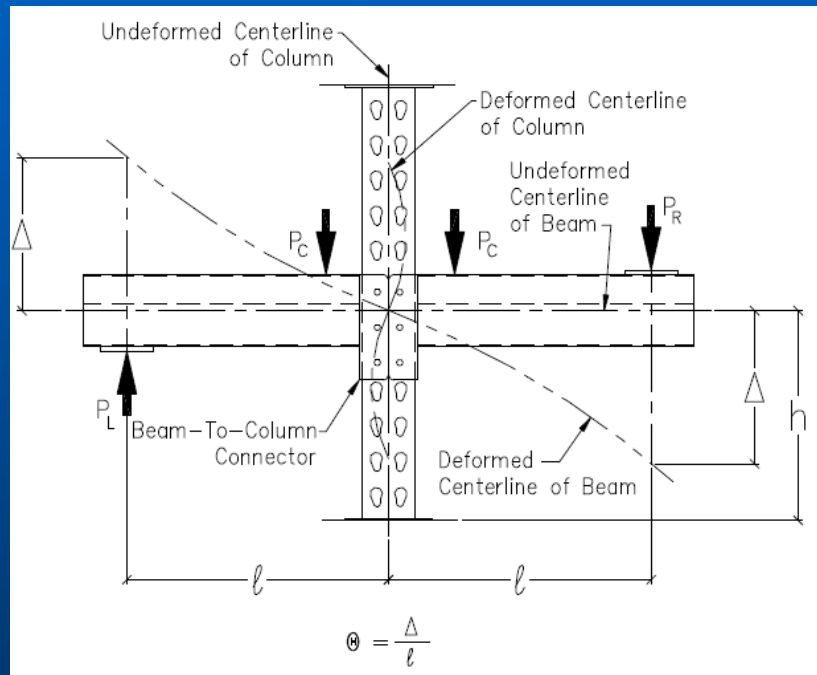

Determining Joint Moment-Rotation Relationship

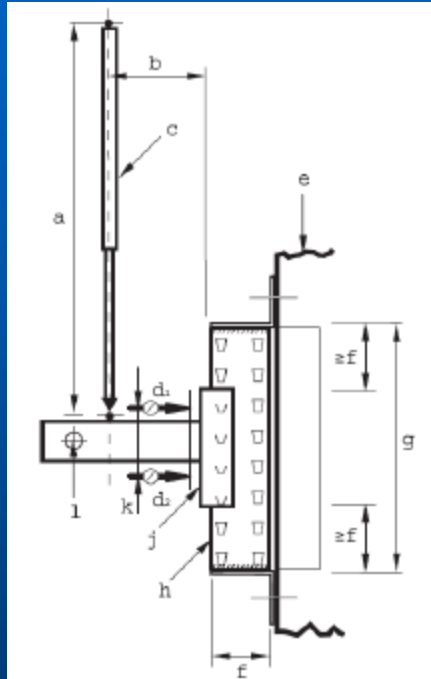

FEM

RMI

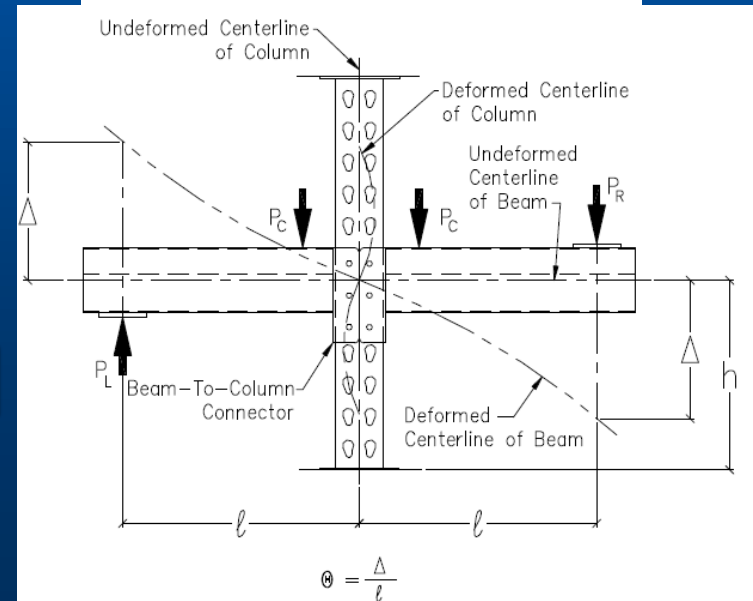
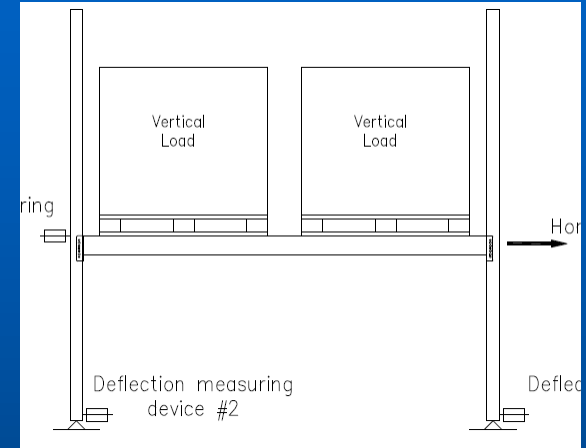

CURRENT AND PLANNED US RESEARCH

- **Planned In-Warehouse Earthquake response observation**
- **Lateral Stiffness studies**
 - **Down aisle**
 - **Cross aisle**
 - **Column base fixity study**

CURRENT AND PLANNED US RESEARCH

- **Lateral Stiffness studies**
 - **Down aisle**
 - **Cross aisle**
 - **Column base fixity study**



Acknowledgement

- **Work carried out part of an on ongoing work (since 1973) to develop and improve RMI Specification**
- **Support of RMI is acknowledged**
- **Parallel and coordinated work in Europe**

Scope

- **Standards and Specifications idealize semi-rigid joint moment-rotation behavior as linear**
- **The study is aimed at representing the true non-linear moment – rotation behavior**

FEM Simulation of Connection Test

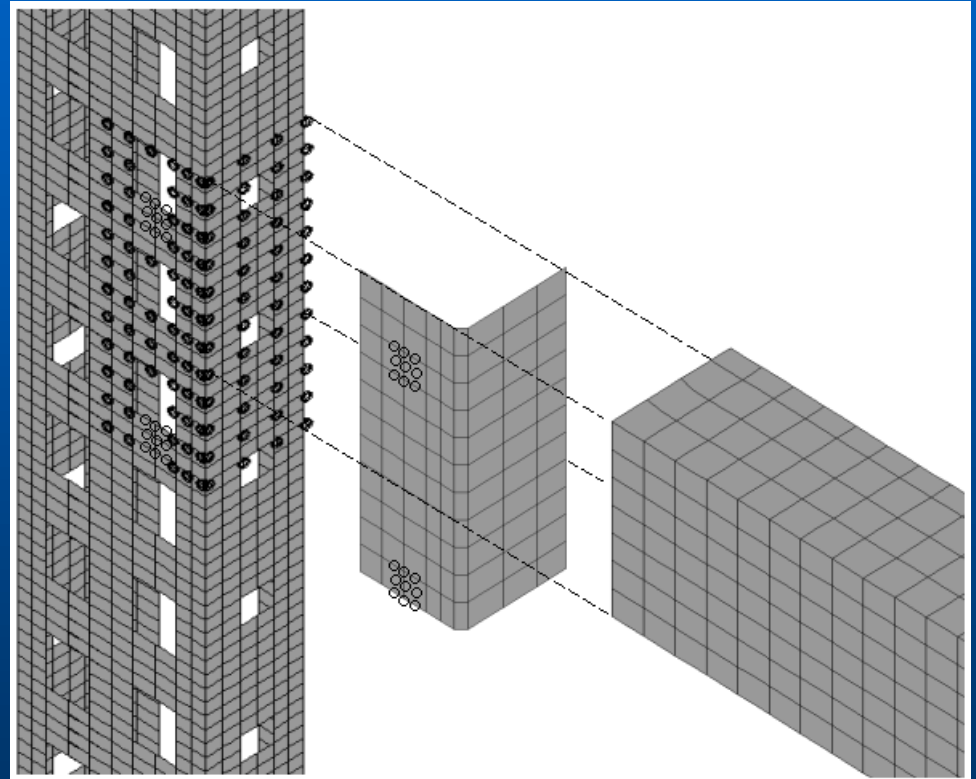
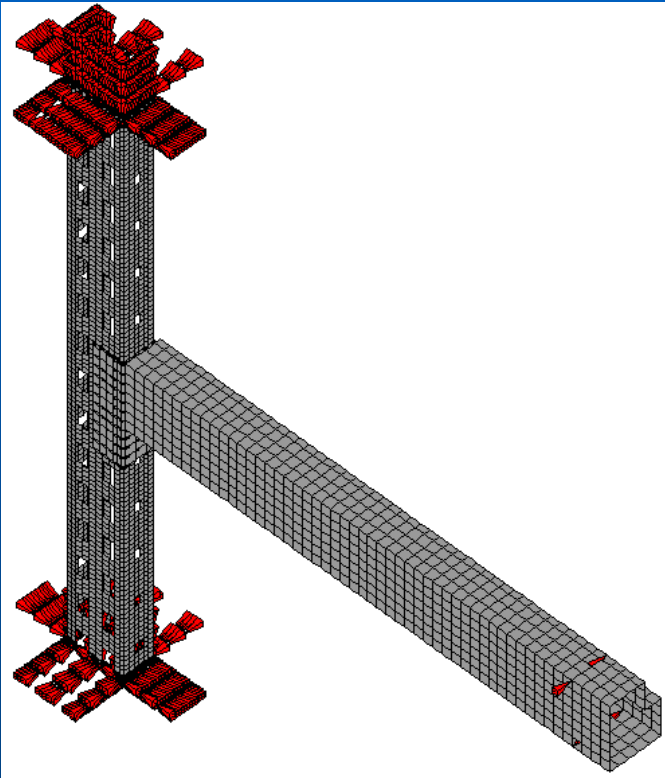

FEM Simulation of Connection Test

VIDEO

Linearizing Joint Moment-Rotation Relationship

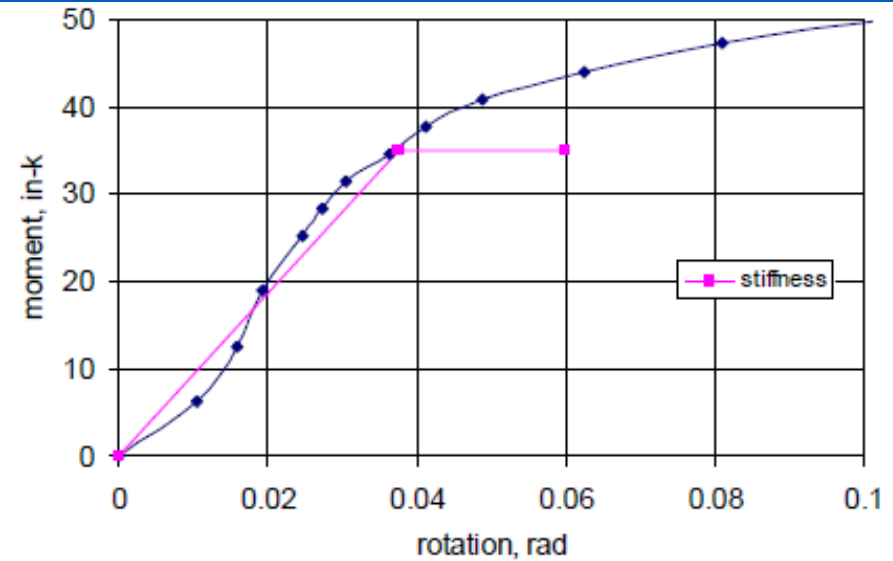
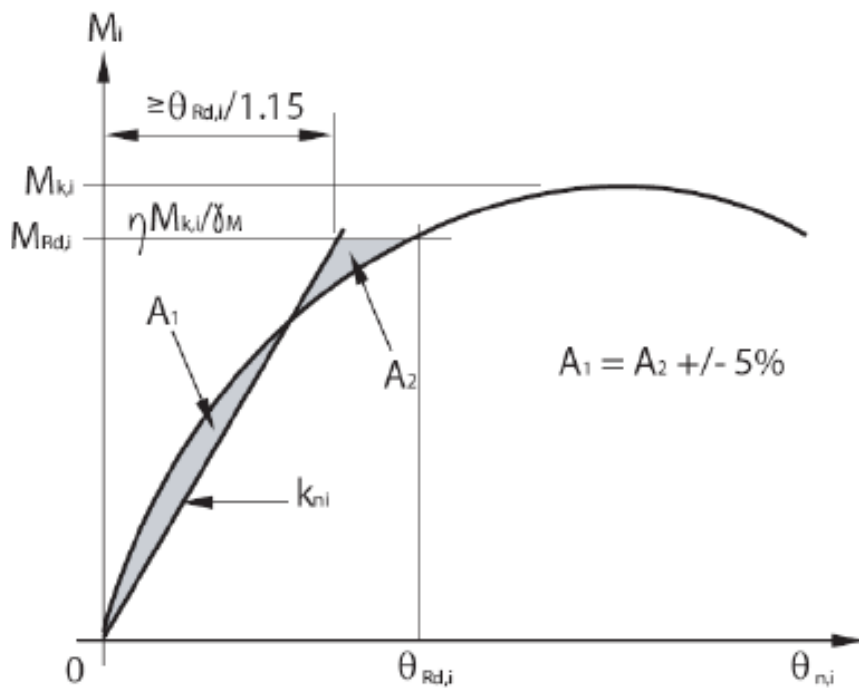

Assumed $M_{Rd} = 35$ in-k, calculated stiffness $k_d = 931$ in-k/rad
 (1 in = 25.4 mm, 1 k = 4.45 kN)

Portal frame

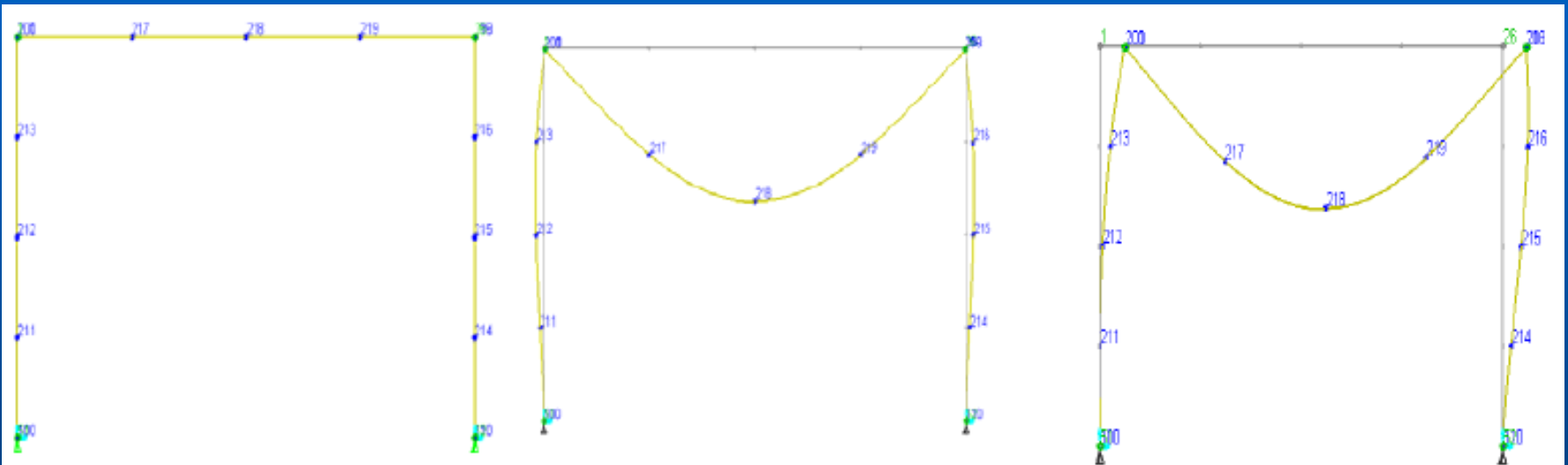
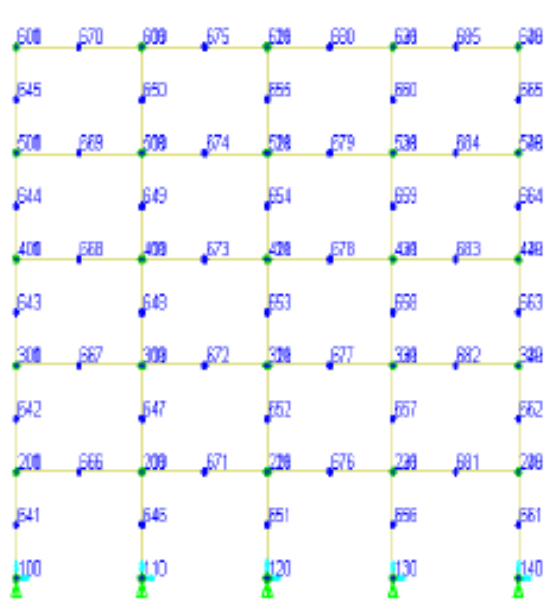

Fig. 5 Portal Frame

Load Case a: Vertical loads on the beam

Load Case b: Load Case a + horizontal load at beam level

Multi story multi-bay frame



Initial shape

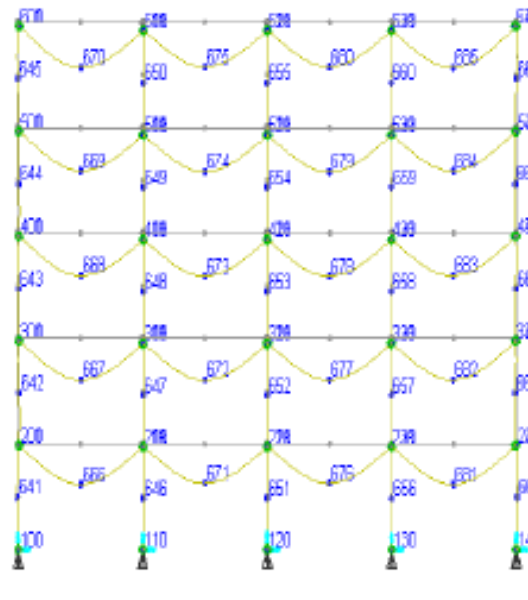

Load Case a

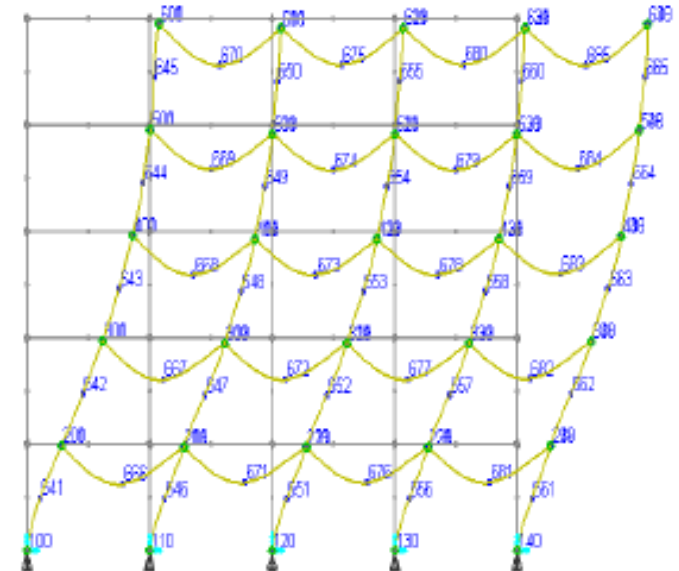

Load Case b

Fig. 7 Portal Frame

Load Case a: Vertical loads on the beam

Load Case b: Load Case a + horizontal load at each beam level

LARSA – 4D DEMONSTRATION

CROSS AISLE STIFFNESS



Objective

To minimize the need for shear testing

CROSS AISLE STIFFNESS

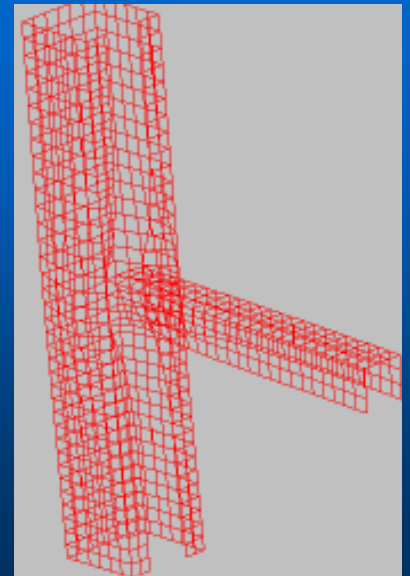
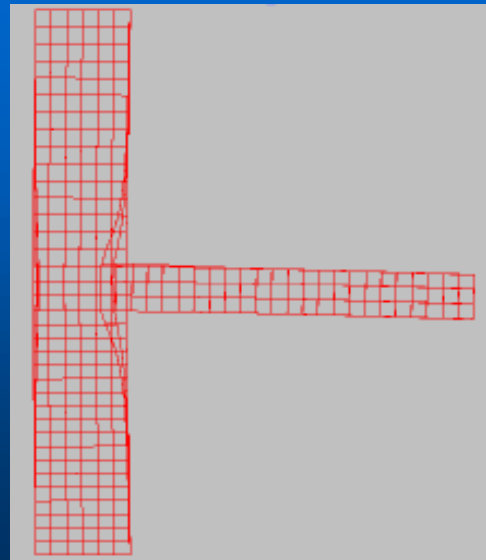
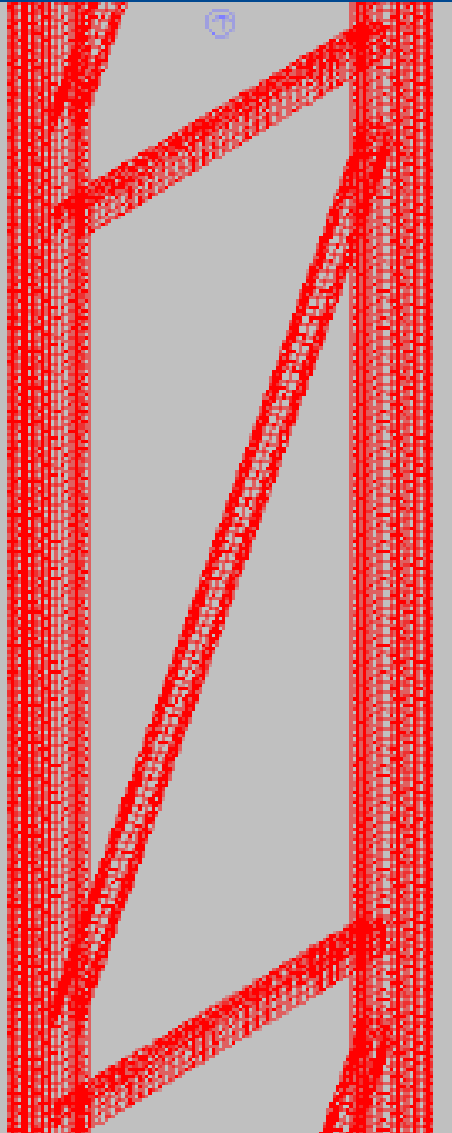
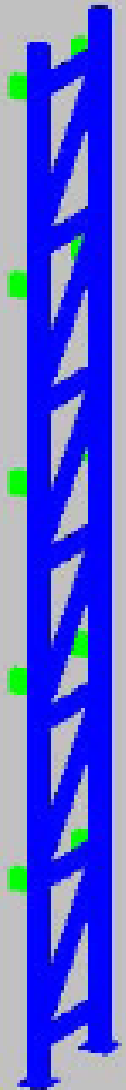

LARSA – 4D DEMONSTRATION

SUMMARY AND CONCLUSIONS